

VT3000



Optional secondary camera



VT3000

FORWARD-FACING CONNECTED VEHICLE CAMERA

This next generation forward-facing vehicle camera offers a cost-effective alternative to a DVR multi-cam solution. The **VT3000** can capture an additional view with an optional digital (IP) internal or external camera – driver, side, rear or cargo facing – for increased visibility and peace of mind. With 4G connectivity, up to 256GB of internal storage capacity and full HD 1080p image quality, the vehicle camera delivers optimum performance for any fleet operation.

Key features:

Industry-leading, connected and HD-quality vehicle camera and telematics system



Provides First Notification of Loss (FNOL) alerts

Provides HD images before, during and after an incident



Accurate G-shock sensor measures impact force and driving style

Monitor driver behaviour from anywhere using the VisionTrack IoT platform



Built-in GPS and GLONASS receiver with self-checking notifications



VT3000

Specifications:

Network	3G/4G	Supports
Positioning	GPS/BD dual mode	Supports
Sensor	Six-axis sensor	Supports
Working status indicator	The indicator light shows the four states of the device:	Power on: the device is powered, the red light is always on Normal operation: green light is always on Fault alarm: indicator red light flashes once a second Sleep: green light flashes 1 second and off 10 seconds
Storage	SD Card	SD card, supports SDXC64GB/128GB/256GB, Supports hot plugging and unplugging
Video & Audio	Video and Audio recording	2 video channels, 2 audio channels
	Resolution ratio and frame	VT-C26-IPC: 720P @ 30fps
	Rate of main code stream	VT3000: 1080P @ 30fps
	Largest resource	Main stream 1080P @ 30 frame +720P @ 30 frame, 2 way sub-stream VGA @ 30 frame
	Image setting	Brightness, color, contrast, color saturation,
	Video coding	H.264 baseline profile/H.264 main profile baseline
	Video compression rate	VT3000: 500Kbps ~ 6Mbps VT-C26-IPC: 500Kbps ~ 6Mbps
	Audio compression standard	G.711U/ADPCM
	Audio compression ratio	4:1
	Audio input	Supports
Camera parameters	Sensor Type (VT-C26-IPC)	1/3" 1.23M pixel CMOS Sensor
	Sensor type (VT3000)	1/2.9" 2M pixel CMOS Sensor
	Shutter speed	1/30sec - 1/100000sec
	Lens/FOV (field of view)	VT-C26-IPC: 2.3mm/115° (FOV); VT3000: 4mm/90° (FOV)
	Lens interface type	M12
	Day-and-night switching mode	VT-C26-IPC: supports; VT3000: doesn't support
	Day-and-night switching mode	Digital wide dynamic
	Backlight compensation	Supports
	Signal to noise ratio S/N	>48db
	Infrared distance IR	VT-C26-IPC: 3m; VT3000: none
Interface	RS232	2 channels
	IO alarm	2 with self-test
	Speed	1 channel
	Power output	5VDC @ 500mA, 12VDC @ 500mA
Protocol	Network Protocol	HTTP, TCP, ARP, UDP, FTP, DHCP, DNS, IPV4, NTP
Power related	Power supply	9-36V
	Built-in battery	Not supported
	Typical power consumption	6W (up to 12W with 12v Power Output Option from GPIO Cable)
General specification	Operating temperature	-30°C~+70°C
	Storage temperature	-40°C~+85°C
	Humidity	0% - 90%
Dimensions	LxHxW	90x39.5x100

VT3000

Dimensions:

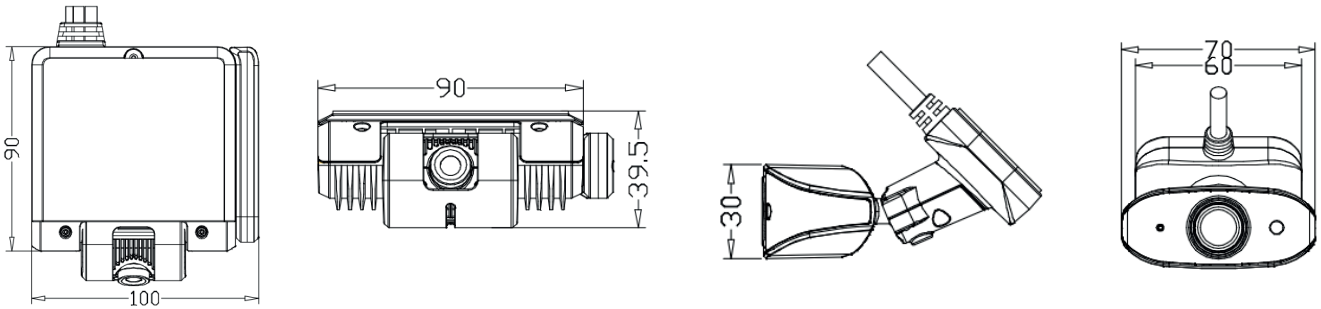

Features:

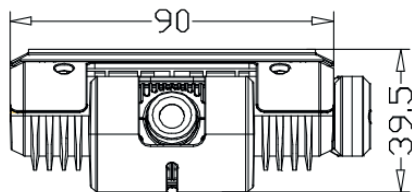
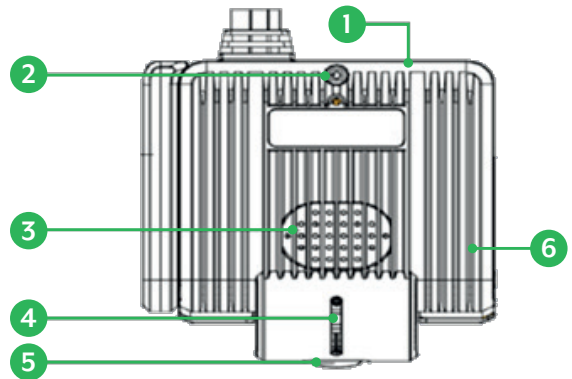
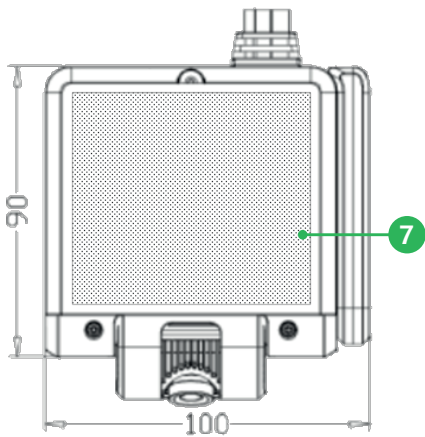

Items Definition

1. MIC
2. Fixing screw of cover
3. Speaker
4. Camera Adjustment Screw
5. VT3000 lens (towards outside)
6. SIM / SD Card / USB Cover Screw
7. Adhesive Pad

